

# *Modeling Human Behavior as a Factor in the Dynamics of an Outbreak of Pneumonic Plague*

P. Jeffrey Potash & John F. Heinbokel  
Center for Interdisciplinary Excellence in System Dynamics, LLP  
c/o Vermont Commons School  
75 Green Mountain Dr.  
South Burlington, VT 05403

[jeffpotash@vtcommonsschool.org](mailto:jeffpotash@vtcommonsschool.org) & [heinbokel@vtcommonsschool.org](mailto:heinbokel@vtcommonsschool.org)  
(802) 865-8084; (802) 865-2429 (fax)

## **Abstract:**

We have an ongoing interest in using system dynamics modeling to provide insights for citizens and policy makers on the impact and implications of human behavior on the course of disease outbreaks. The idea that humans might behave in ways not predicted by rational disaster planning efforts seems to be largely overlooked. In this paper we describe our efforts to understand and to simulate the ways in which three specific behaviors -- fleeing, seeking care, and isolating oneself -- affect the simulated course of an outbreak of pneumonic plague in a city of 1.5 million inhabitants. This model was initialized to represent Surat, India and then used to explore a pneumonic plague outbreak in September 1994.

Our work proceeded through several phases. We first constructed a basic S-E-I-R model of the transmission of pneumonic plague through an urban population of 1.5 million inhabitants. Data from analyses of early 20<sup>th</sup> century outbreaks in San Francisco and Manchuria and a more recent one in Madagascar. This model was then used to initialize to represent Surat, India, and used to explore the impact of human behaviors on the course of the simulated outbreak, using the real data from Surat to evaluate the model. With the basic disease model in hand, we then added the observed availability of antibiotics to the model as well as structures to represent the three behaviors of interest. The known availability of antibiotics was markedly inadequate in providing the necessary effect to replicate the observations. Even when the model incorporated the fleeing of the estimated 30% of the population who abandoned the city, the modeled disease failed to resolve itself as rapidly as was observed in reality. Only when the third behavior, reduction of the person to person contacts by a factor of about 70%, was added did the model produce a close fit to the data. This latter factor was barely acknowledged by several prior analyses of the outbreak; without it, no reasonable combinations of modeled parameters produced the observed control.

The human behaviors studied in this model were all applied exogenously. Our current efforts are focused on working to define these behaviors as endogenously controlled dynamics within the boundaries of the simulated Surat outbreak.

## **Introduction:**

Modeling diseases as a part of disaster planning and response requires projecting the dynamics of the basic disease and how the society's response will change (ameliorate the effects of) those dynamics. The modeling effort described in this paper grew out of preliminary efforts to build predictive models 1) to aid in projecting the impact or effectiveness of a number of policies that could be used in controlling an outbreak as well as 2) to aid in predicting the social, political, and economic impacts of either a short-term, acute outbreak or a longer-term, endemic presence of the disease. The agency sponsoring this work specified bubonic and pneumonic plagues, as the diseases of interest. At this point in the development of these models, we have remained focused on pneumonic plague as the simpler to model since it lacks the need to include the rodent and flea vectors that bubonic plague requires. Pneumonic plague is also the more likely bioterrorist threat, an issue that has gained importance in recent years.

As the modeling effort proceeded, we found it ever more necessary to test the structures and assumptions of that developing simulation. Did we have a reasonable depiction of the spread of pneumonic plague? Apart from the biological or medical dynamics of the disease, had we included a reasonable and sufficient set of responses in terms of individual behaviors and social policies to represent the human behavioral dynamics adequately? Before moving on to begin closing the feedback loops that would make the human behavior dynamics of the model endogenous or to use the simulation for serious predictive purposes, we turned to a modern outbreak of pneumonic plague to provide a reference case against which to test our model.

Surat, India experienced a significant outbreak of pneumonic plague in September, 1994. In the accounting that followed the end of the episode, its overall impact appeared relatively light, at least compared to those of the three prior global pandemics of plague (Shah, 1997). The accounting is not perfect, but nearly 900 cases were recorded, of which “only” approximately 50 died. Perhaps even more significant, despite the relatively low number of cases and fatalities, the community life of Surat was profoundly disrupted, as about 30% of the population fled the town. Local and regional economic impacts were severe. At the national level, foreign trade and international passenger carriers were affected with an estimated total economic impact on the order of \$2 billion.

## **Modeling Pneumonic Plague:**

Pneumonic plague is one variant in a family of diseases caused by the bacterium *Yersinia pestis*. Bubonic plague is the most common form of this family; it spreads through the bites of fleas that acquired the plague bacteria from infected rodents. The incubation period of bubonic plague is longer than for pneumonic and, while frequently deadly, is not as deadly as the pneumonic form. Pneumonic plague is spread from human victim to human victim through respiratory aerosols, released during coughing. A relatively low fraction of bubonic plague sufferers spontaneously develop “primary” pneumonic plague; such “index cases” can then begin a chain of efficient and deadly person to person transmissions of “secondary” pneumonic plague.

As long as we are interested in a relatively short-lived outbreak of pneumonic plague, we can simplify our modeling task considerably by ignoring births and non-plague deaths in the affected

human population as well as any rodent-flea dynamics that would be required for bubonic plague. We began our modeling within an epidemiologically familiar S-E-I-R framework (e.g. Sterman, 2000) that recognizes four basic categories of individuals in a disease transmission chain: 1) Susceptible individuals; 2) Infected (or Exposed) individuals who are incubating the disease, but are not yet symptomatic or contagious; 3) Ill and Contagious individuals; and 4) Individuals who have been Removed from the disease chain through recovery (with resulting immunity) or death. The basic structure of such an S-E-I-R model of pneumonic plague is illustrated in Figure 1.

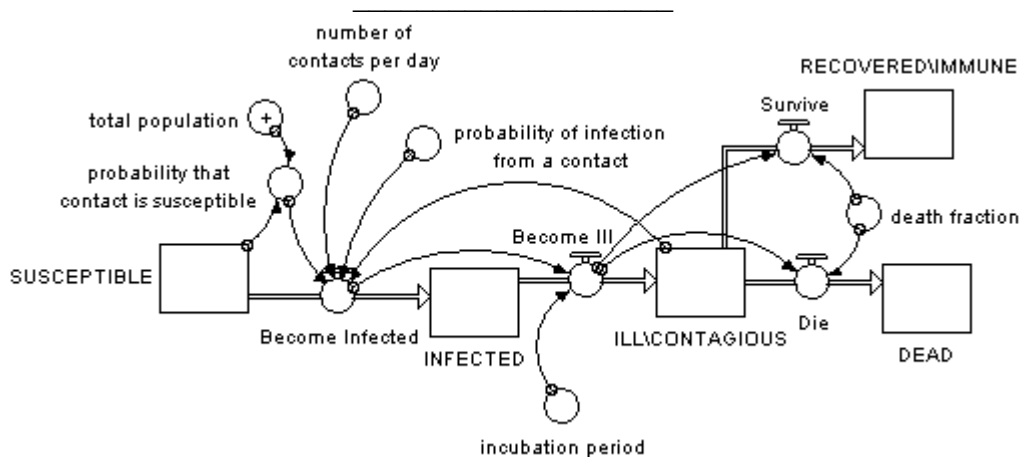

Figure 1: Basic S-E-I-R model that serves as the foundation for the analysis of the Surat outbreak.

The dynamics of this disease begins with the introduction of one or more ill and contagious individuals into a previously disease-free population. Others then “Become Infected” at some rate (per day) defined as the product of:

1. The number of contagious individuals in the population,
2. The average number of contacts with others that each contagious individual has,
3. The probability that a given contact is susceptible to infection, and
4. The probability that a given contact with a susceptible individual will lead to infection.

Individuals remain in the INFECTED stock for a period of time known as the incubation time for the disease. This is variable among individuals and depends on the overall health and resistance of the infected individual and the size of the infecting dose of bacteria; for pneumonic plague this can vary from 1 to 6 days with most typical values in the 2-4 day range. Bombardt (2001), in an analysis of two historical outbreaks estimated incubation times of 2.8 and 3.2 days; we have used a mean value of 72 hours in our modeling.

Once the symptoms of the disease appear (including lung congestion, coughing, and dispersal of respiratory aerosols), pneumonic plague is rapidly and overwhelmingly lethal in the absence of quick application of antibiotics (i.e. within the first 18 hours after the appearance of symptoms). Death occurs in approximately 95% of untreated individuals. Death occurs from 1 to 5 days after the onset of symptoms; again, based on Bombardt’s (2001) analyses, we have used an average death time of 84 hours.

A fundamental parameter in traditional epidemiological modeling is “ $R_0$ .” That reflects the number of new infections each currently infected individual will cause to happen. Many who model disease dynamics assume that the “ $R_0$ ” functions as a constant that is characteristic of the specific disease; the model presented here does not make that assumption. In our modeling that parameter is explicitly replaced by three elements that serve the same purpose: “probability that contact is susceptible,” “number of contacts per day,” and “probability of infection from a contact.” Each of these elements can be modeled dynamically, leading to a dynamic and changing “ $R_0$ .” In addition, the latter two elements provide logical foci for efforts to control the course of a given outbreak. While we do not use “ $R_0$ ” as a fundamental “driver” in this model, we can calculate its value at any time during a model run.

### **Modeling Pneumonic Plague in a Modern Medical Context:**

This relatively simplistic S-E-I-R model of a disease with such a high mortality rate typically leads to a simulated scenario in which virtually everyone in the population is infected and most die as a result. Diseases where a significant fraction of the infected can recover with subsequent immunity (e.g. influenza, smallpox, measles, etc) produce very different dynamic patterns. In fact, however, modern medicine is capable of intervening effectively in outbreaks of bacterial diseases, such as plague, through combinations of immunization, antibiotic treatment, and supportive treatments such as fever control and regulation of hydration. Even in the absence of effective medical intervention, behavioral dynamics can profoundly alter that simplistic projection.

Modern medical science presents several leverage points for affecting the basic disease transmission chain and the mortality of a given disease. Figure 2 adds these to the earlier depiction of the S-E-I-R model.

1. **Medical Care:** Administration of antibiotics can alter the mortality fraction of those afflicted. The speed with which the diagnosis is made and the proper antibiotic regime is begun, the degree of antibiotic resistance displayed by the bacterial strain, the prior physical condition and any underlying compromise of the immune system, and the proper timing and completion of the antibiotic regime, are all critical factors that can affect this dynamic. In addition, modern medical care provides symptomatic relief and life support such as respiratory therapies, fever control, hydration and nutrition maintenance. In our model, if antibiotics are provided to an ill individual within 18 hours of the onset of symptoms, the prognosis is altered from a 5% probability of survival to 90%.
2. **Prophylactic Provision of Antibiotics:** Susceptible individuals and people exposed, but not yet symptomatic and contagious, may receive antibiotics to prevent infection, prevent development of the illness, or reduce the severity and duration of the illness. The most efficient approach is to provide antibiotics only to those known to be exposed to the infection; often, however, those people cannot be distinguished from unexposed but susceptible individuals, and all symptom-free individuals become eligible for prophylactic antibiotics.

3. Immunization: This is not, in fact, a current option for pneumonic plague, although a vaccine providing some protection for bubonic plague has been available in the past, and intense research efforts are working on this (e.g. Canada Newswire, 2003). We include the Immunization flow in Fig 2 to illustrate that generic possibility, but we will not discuss it further in the context of this paper.

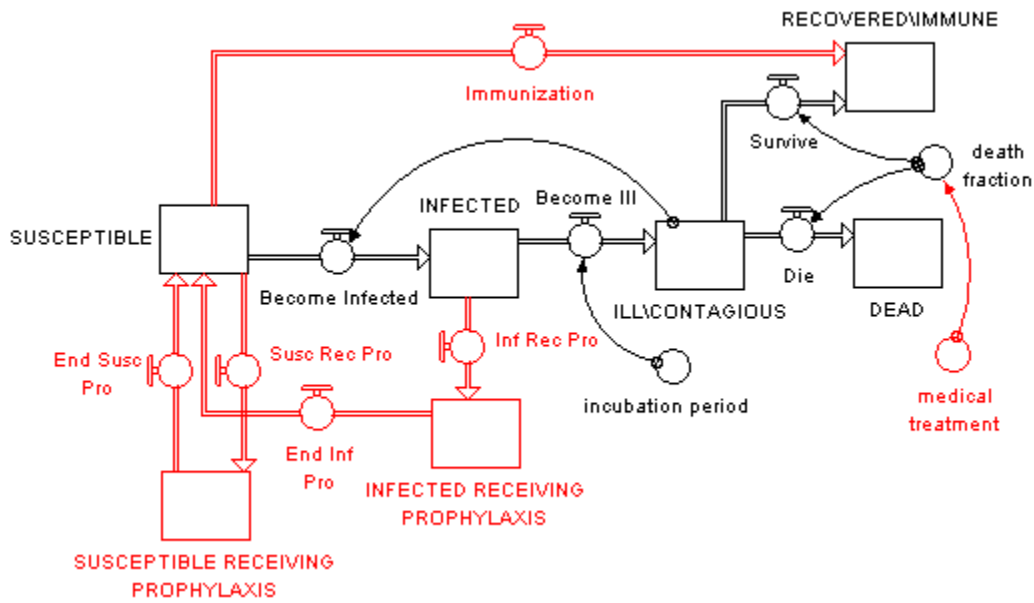

Figure 2: Conceptual map of the medical interventions (receiving prophylactic antibiotics, immunization, and medical treatment) that can affect the dynamics of the basic S-E-I-R model of disease transmission. The core transmission model is the same as presented in Figure 1, albeit with the factors controlling the “Become Infected” flow hidden for simplification.

### Modeling Pneumonic Plague with an Added Social Context:

Besides the options provided by modern medical care, individuals and societies have behavioral responses that can affect the course of an infectious outbreak. These predate the development of modern medical and public health approaches, and they still represent powerful leverage in controlling a community outbreak or, on a smaller scale, the likelihood of an individual contracting the disease. Figure 3 adds these elements to the developing model of pneumonic plague.

Conceptually, we need to be concerned with individual (behavioral) responses as well as governmentally mandated (policy) actions. An assumption included in many models of disaster management scenarios holds that people will behave as expected (or instructed). The changing and changeable nature of human behavior is largely discounted. Collectively these responses fall into three broad categories: freeze, fight, and flee:

1. Isolation: Individuals may be instructed to limit their contacts with others (e.g. quarantine) or choose on their own to isolate themselves.
2. Seeking Medical Care (or refusing to): Here again both individual and societal influences can be seen. Is a sufficient medical infrastructure available and/or can the existing resources be adequately supplemented to meet an increased need? How will individuals' social and economic status and their prior experience with and faith in those medical resources act to define their willingness to utilize those available resources? How well has the medical system managed the current outbreak to the point in time?
3. Fleeing: How many individuals will choose (or be permitted) to flee the locale of the outbreak?

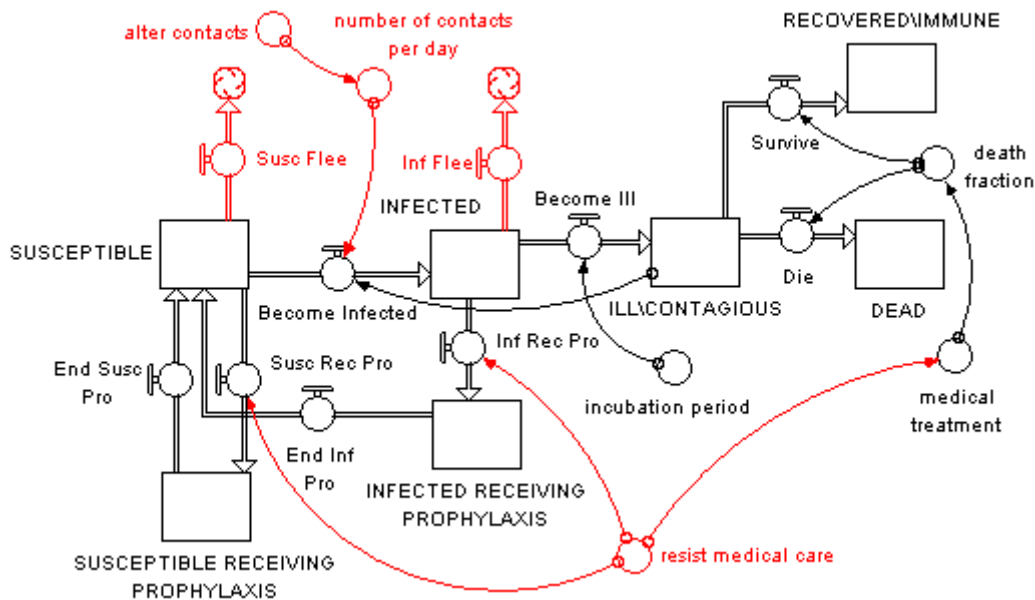

*Figure 3: Conceptual map of the social or behavioral factors (fleeing, resisting or refusing medical care, and limiting the number of contacts) that can affect the dynamics of the basic S-E-I-R model of disease transmission. The core transmission and medical intervention model is the same as presented in Figure 2.*

### **Modeling Pneumonic Plague in Surat, India, September 1994:**

The preceding discussion outlines the development of a computer simulation designed to model an outbreak of pneumonic plague. This model contains a basic disease transmission structure, an element of response in terms of distribution of antibiotics by the medical and public health sectors, and exogenous behavioral and policy features. Ideally, those human responses would be defined endogenously by the dynamics of the simulated disease and of the community's response, but for the purpose of illustrating interactions and implications, we have kept both

factors exogenous to the operation of the model so that the user can explore the possible range of interactions and impacts. In this model of pneumonic plague, we present the user with the opportunity to control both "community response" decisions as well as to impose some human behavioral responses into the scenario.

### Surat: The Setting

Located in the western state of Gujarat, Surat was one of India's fastest growing cities in the years after World War II. Between 1951 and 1991, Surat's population grew from 237,000 to approximately 1.5 million residents, with a corresponding increase in actual physical size from 24 sq km in 1961 to 111 sq km in 1991. The "old city" or city center remained the most heavily populated region of Surat, accounting for 77% of the total population with a population density fully four times greater than the city average (13,483 per sq km). The newer settled, outer portions of the city, particularly to the north (Ved and Katargam), south (Pandesarra and Bhestan) and east (Varachha and Aswinikumar), were characterized by their universal lack of planning. Incorporating a mix of industry and lower class residences, these areas were largely devoid of proper sewage facilities (fewer than 13% of the city's populations were linked to sewage facilities), and were described by residents as "floating on sewage water" (Shah, 1997). Less than half of the city had access to treated drinking water. The unhygienic conditions and poor working conditions within Surat were commonly cited by public health officials as the causes for regular epidemic outbreaks within the city, typically three or four each year, with malaria, gastroenteritis, pneumonia, and diarrhea being the most common (REFS).

Prior to the plague outbreak in 1994, Surat had not experienced any plague deaths for almost four decades. In terms of medical facilities, there were 310 hospitals in the city, providing nearly 5,000 beds. The two largest facilities, the "old" and "new" civil hospitals had a total of 740 beds; the latter became the designated treatment center for suspected plague victims. In addition, there were about of 2200 registered medical practitioners engaged in private practice in Surat. The majority of these (60% of the total), however, were traditional (non-Western) practitioners functioning among the poor and in slums.

### Surat: The Outbreak

Much of what is "known" about the Surat outbreak has been reconstructed after the fact, since especially the early events took place before the identity of the disease was known and appreciated and before the New Civil Hospital was designated to receive all new cases.

In hindsight, the Expert Committee of Doctors, appointed by the Government of Gujarat to investigate the epidemic, identified the death of a 35 year old man on 12 September 1994 as the "first case of death." He had been admitted to the Ashakta Ashram Hospital on 9 September with respiratory symptoms and fever (Shah, 1997). Over the next week or so, through 20 September, approximately 15 individuals were admitted to various hospitals, mostly to be diagnosed with and treated for malaria. On 21 September the presumption of plague was made at the New Civil Hospital and treatment of patients and staff with tetracycline was begun. Public health authorities were alerted, word began to spread through the medical community, and the New Civil Hospital was designated as the municipal center for new admissions. During the late

hours of 21 September and early 22 September, shops began closing in the most heavily impacted region of the city (Ved Rd.), medical practitioners began to leave the city (and were observed by their neighbors to be doing so), and local medical shops sold out of available tetracycline. Hospital admissions continued to grow and public health authorities were barely able to locate sufficient antibiotics to treat the ill and their care-providers; however, by the end of 22 September the mortality rate for new cases had dropped to below 10% from its initial value in excess of 80%. Over the next 48 hours, until adequate government supplies of tetracycline begin to arrive, approximately 30% of Surat's population fled. Businesses closed and public facilities (schools, swimming pools) shut down. Private organizations mobilized limited additional supplies of antibiotics. By 25 September, adequate stocks of antibiotics were arriving and teams were being mobilized to move through the community to identify affected households and to provide antibiotics to those families and their neighbors. By the end of September, the outbreak had effectively ended (Garrett, 2000; Shah, 1997).

### Surat: The Model

The Surat outbreak provided us a data set that enabled us to accomplish two tasks: 1) test the basic disease model against a reasonably accurate reference scenario, and 2) examine the impact of a variety of behaviors and policies, particularly to explore whether the behaviors that our mental models had suggested could be documented, quantified, and were, in fact, adequate to reproduce the observed data.

Figure 4 depicts the basic stocks and flows of the model we tested; it differs from that presented earlier only in several aspects:

1. Antibiotics will not be universally successful in warding off infection. Some SUSCEPTIBLE individuals who receive antibiotics prophylactically will still contract the disease. The same is true of some ILL individuals, even if they receive antibiotics within the normally adequate 18 hour window.
2. Those who become symptomatic will experience an 18-hour window during which the start of antibiotic treatment will usually lead to recovery. As with prophylactic antibiotics, treatment is not inevitably successful and even some untreated individuals may recover, although that latter fraction will be quite small.
3. TREATMENT (antibiotics, in this case) may be present in limited supply. First priority for the available antibiotics will be to treat those who are ill; if adequate supplies are available after treating all the ill, then asymptomatic individuals (SUSCEPTIBLE and INFECTED) can receive the excess.
4. The TREATABLE ILL stock (conveyor) contains those individuals within their first 18 hours of symptoms and contagion. If started within that time frame antibiotic treatment is usually effective



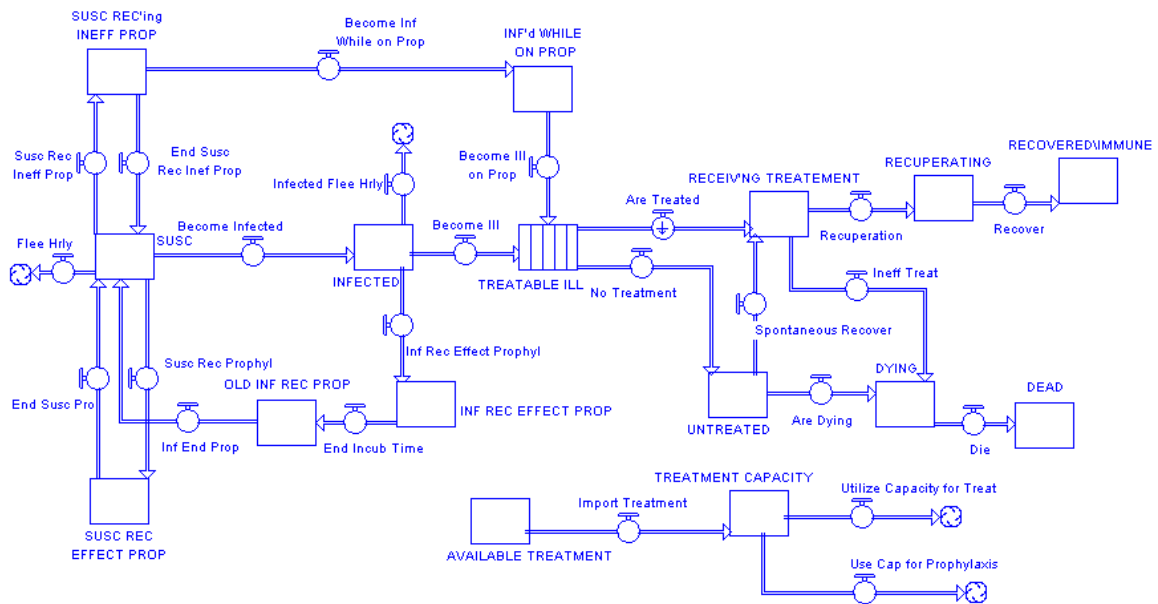

Figure 4: Stock-Flow structure of the complete simulation of the September 1994 Surat outbreak of pneumonic plague.

While our interest here is in exploring Surat specifically, we also constructed a “Control Panel” to the model so that the simulated dynamics could be applied to other settings and the simulation initiated with different starting conditions. Default conditions reflect Surat, but those could be altered to develop other scenarios. Figure 5 illustrates that “Control Panel”; not all the factors that can be altered from the control panel will be discussed in this contribution.

### Control Panel for a Simulation

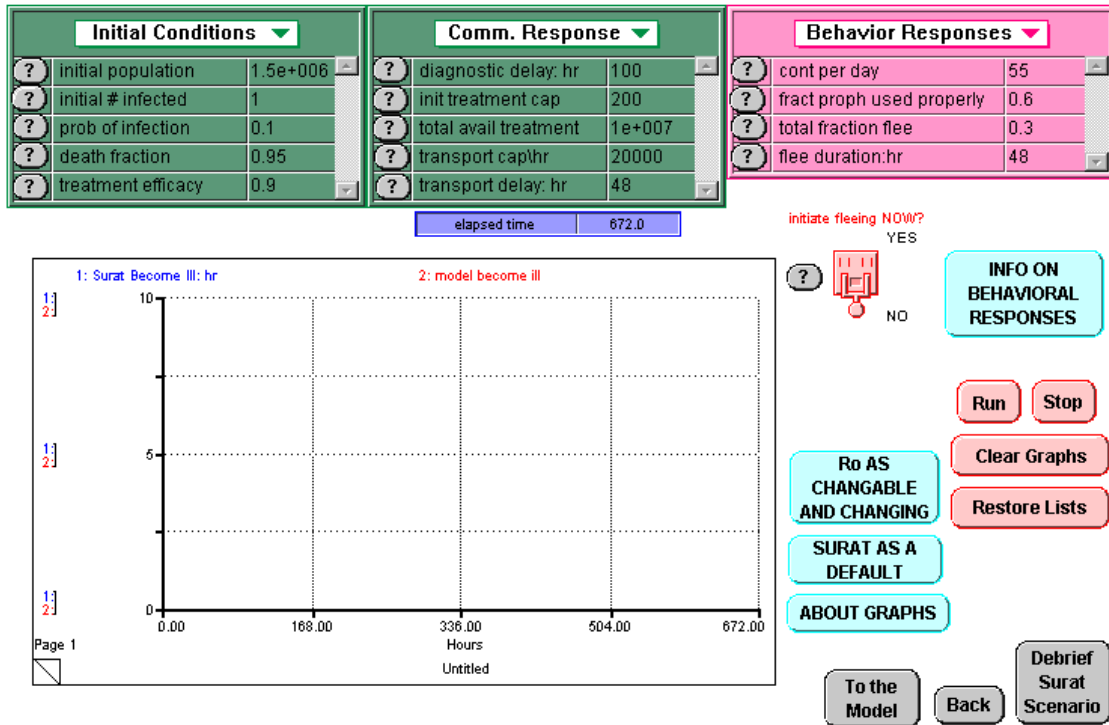

Figure 5: Control Panel for the generic pneumonic plague simulation. The default conditions (shown here) are the starting data to depict Surat, India in September 1994. The first two graphs on the graph pad compare the model results to the actual data from that Surat outbreak. Other settings and scenarios can be simulated by changing these defaults.

We proceeded stepwise:

1. Test and Fine-Tune the Basic Disease Transmission Model: The data incorporated into the model on the timing of the various disease stages and on the mortality rate are well established in the literature. Our “probability of infection from a contact” factor was derived from real data (Bombardt, 2001), and while critical to the model, was not subjected to further testing. Of most concern, however, was the “number of contacts per day.” This is very much situation-dependent; rural environments would likely be characterized by low values, while dense urban settings, like Surat, would have high values. We used the first portion of the Surat scenario, where the data were unaffected by medical care or behavioral factors (i.e. the first 280 hours), to fine-tune this factor. The model result, using 55 contacts per day, is illustrated in Figure 6. This is the value we used for the initial portion of the Surat simulations and in all subsequent explorations.

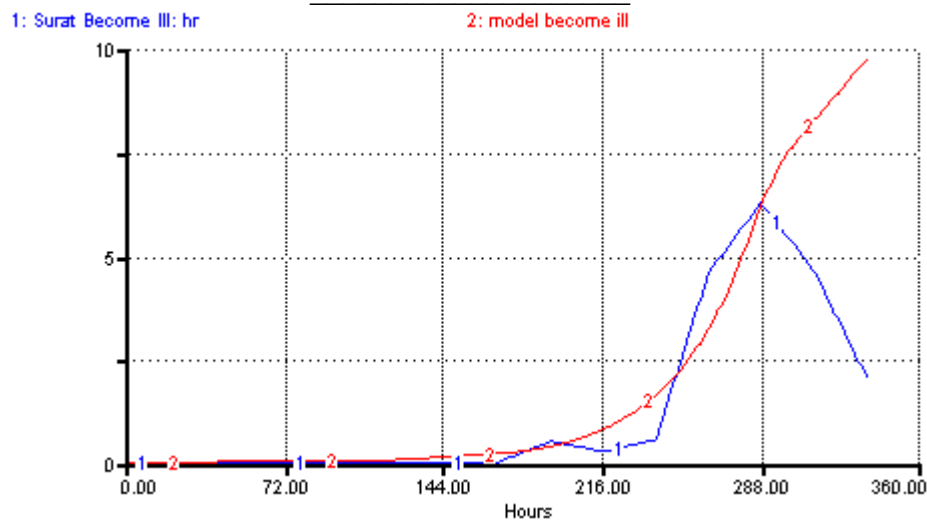
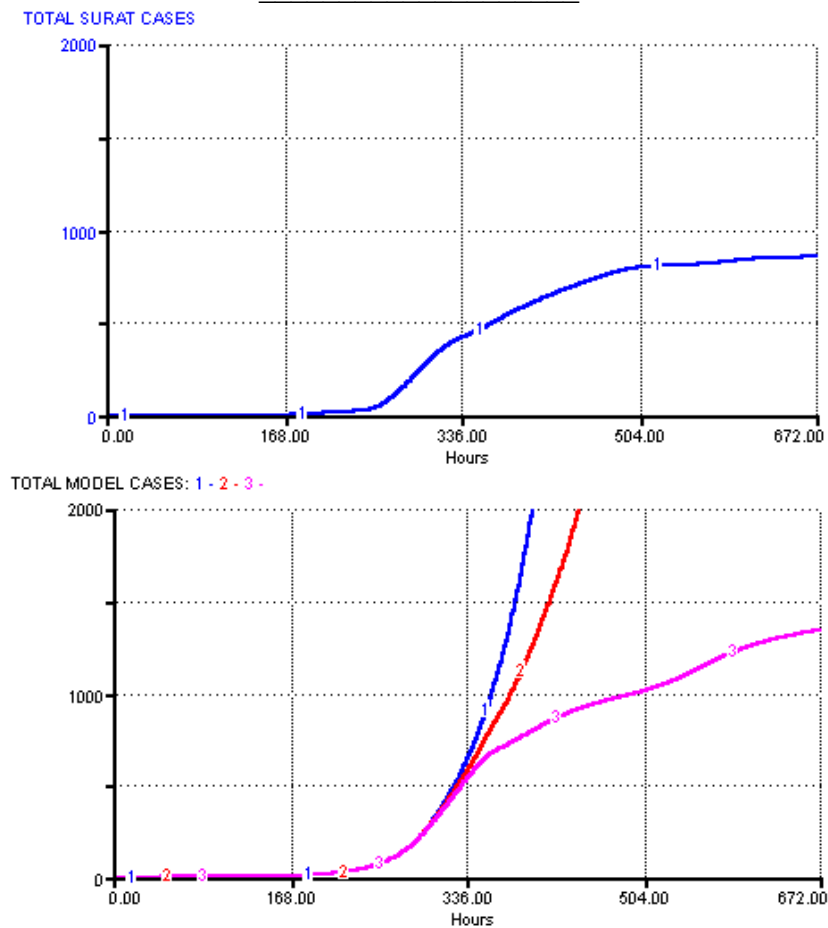

Figure 6: Output of the model (line 2) when run with no medical or behavioral responses to the initial infection. This output can be compared to the actual tabulated rate of new cases (line 1). This analysis was used to fine tune the parameters that define the rate at which the model creates new cases

2. Test the Impact of the Documented Provision of Antibiotics: We know from the various accounts of the Surat outbreak that antibiotics were (barely!) sufficient for those who were ill throughout the outbreak, but that sufficient supplies for widespread prophylactic distribution did not begin to arrive until about two days after the diagnosis had been made. At that time, however, wide distribution began and shortly after that, the outbreak faded out. How confident can we be that this provision of antibiotics by the medical and public health communities was sufficient to halt the further spread of pneumonic plague? We tested that with our model by simulating the documented importing and distributing of tetracycline. Two factors are critical: 1) at what rate were the antibiotics made available to the population? and 2) with what efficacy did the population utilize those resources? One account of the outbreak claimed that fully 90% of the population FAILED to use the antibiotics correctly. We are unwilling to extrapolate that and assume, therefore, that only 10% of the population was protected (even suboptimal administration of antibiotics may well provide some degree of protection!), but some correction factor is called for. Figure 7 presents the results of these tests.

The top panel of Figure 7 presents the cumulative total number of cases as documented by the New Civil Hospital, the facility designated by the government to serve as Surat's treatment center. A total of 858 cases were reported (Shah, 1997). The bottom panel shows the model's prediction of cumulative total cases with the known supply of antibiotics entering the city and being distributed. The three curves are derived from different assumptions on the degree to which these antibiotics conferred protection:

- Curve1: 10% of recipients were protected (most antibiotics were used improperly)
- 2: 60% protection
- 3: 95% protection



*Figure 7: Effect of antibiotic prophylaxis. The top graph contains the actual data for Surat's cumulative cases of pneumonic plague during September 1994. The bottom panel presents model output from runs that include the rate at which prophylactic antibiotics were provided. The three curves represent different levels of protection provided by the antibiotics:*

*Curve 1: 10% of recipients protected (most use the antibiotics incorrectly)*

*Curve 2: 60% of recipients protected*

*Curve 3: 95% of recipients protected*

*Curve 3 exceeds any reasonable expectation of protection and is still not sufficient to bring the model output into alignment with the documented reality.*

Even with almost perfect usage (not at all the scenario that was reported!) the documented distribution of antibiotics would have been insufficient to halt the outbreak as rapidly as it was halted. The final number of cases in each model run were:

- Curve1: 166,000 cases (most antibiotics were used improperly)
- 2: 56,000 cases
- 3: 1,350 cases, and still rising

In later model explorations, we use the intermediate (60%) value for antibiotic effectiveness; neither of the more extreme values seems reasonable, although we do NOT have data to support a value of precisely 60%.

3. Test the Impact of People Fleeing: Despite the danger of taking active pneumonic plague into surrounding communities and against the instructions of the authorities, about 30% of Surat's original population of 1.5 million were estimated to have fled the city in the two days immediately following the diagnosis and disclosure of pneumonic plague. To test the effect of that out-migration, we adjusted the model to remove, over a 48 hour period beginning at hour 263, 30% of the SUSCEPTIBLE and INFECTED populations. We assumed that those who might already be on prophylactic antibiotics would have little reason to flee and those who were already ill would be unable. Either assumption can be challenged. We maintained a prophylactic antibiotic efficacy of 60%. Figure 8 displays the resultant predictions.

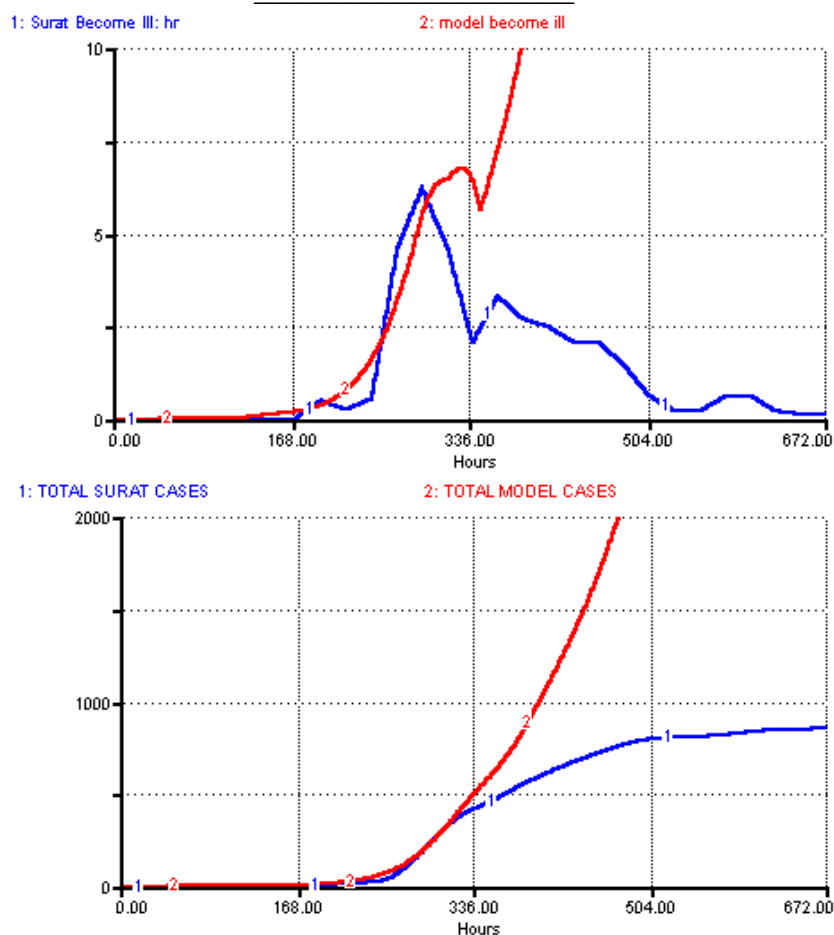
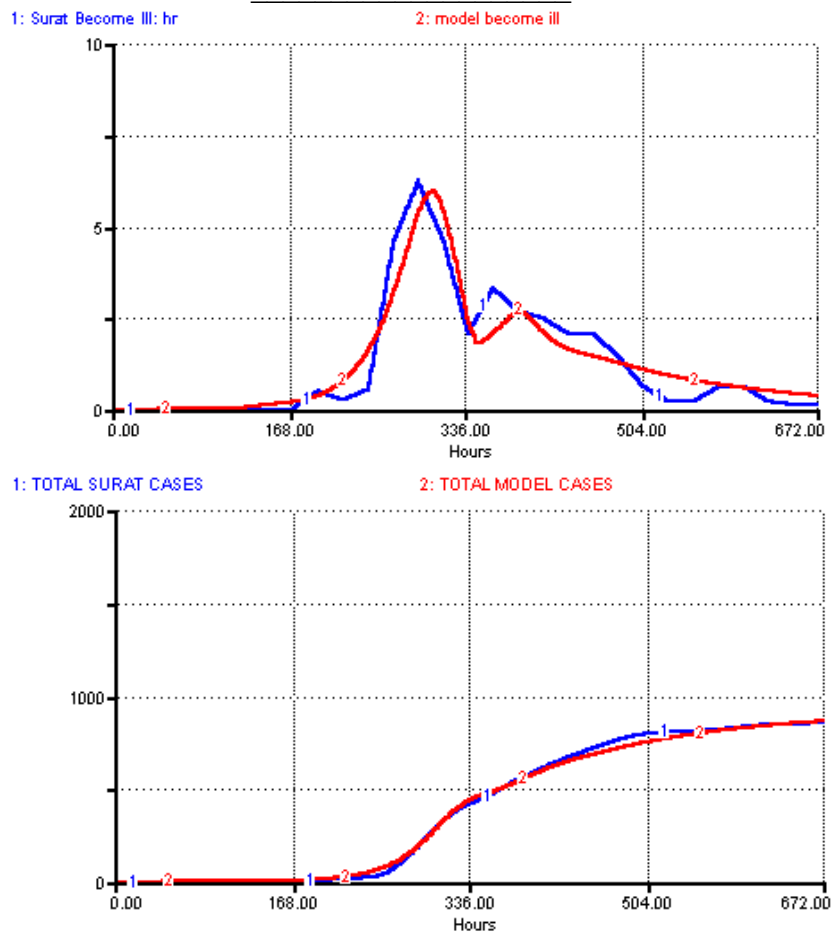

*Figure 8: Actual Surat data and model predictions of the rate of new cases (top panel) and the cumulative cases (bottom panel) for models in which antibiotics are provided and used with 60% efficiency and in which approximately 30% of the population flees in the first 48 hours following announcement of the presence of plague in Surat.*

In the upper panel, the model predicts that hourly cases continue to rise throughout the simulation, reaching 65 new cases/hour by the end of the simulation. Total cases reach approximately 9,000 by the end of the run. Recall that with a 60% level of antibiotic effectiveness and without a portion of the population fleeing, the number of total cases was about 6 times higher. Fleeing is significant in its impact, but not sufficient to account for the rapid ending of the Surat outbreak.

4. Test the Impact of Isolation: Accounts of the outbreak spoke of schools, public swimming pools, and businesses closing. Shah (1997) mentioned, almost casually, that when surveillance teams began to canvas the neighborhoods, they reported the streets as almost deserted. All of this suggests that the population who remained in the city chose, on their own initiative, to isolate themselves, thus reducing the number of contacts that each infected individual might have.

Our assumption is that people would begin isolating themselves when they become aware of the outbreak, essentially the same point in the simulation that others in the community would choose to flee. In the model run shown in Figure 9 we reduced the “contacts per day” from 55 to 17, about a 70% decrease at hour 263. The documented availability of antibiotics, used with 60% efficacy, and the 30% of the population fleeing remain in the model; isolation is added to those features



*Figure 9: Actual Surat data and model predictions of the hourly rate of new cases (top panel) and the stock of cumulative cases (bottom panel) for models in which antibiotics are provided and used with 60% efficiency, in which approximately 30% of the population flees in the first 48 hours following announcement of the presence of plague, and in which the remaining inhabitants reduce their contacts (voluntary “quarantine”) from 55/day by about 70% to 17/day*

The “eyeball” fit of the modeled parameters to the real data appears quite close. To provide a more objective measure of that, however, we turned to the Theil inequality statistics (Sterman, 2000), using a STELLA sub-routine created by Dr. John Sterman and provided to us by Dr. Kevin O’Neill. We tested the two parameters illustrated above: the hourly number of newly diagnosed cases and the total cumulative number of cases, recognizing that these are closely related. The results of that analysis are presented in the Table 1 below.

---

	New Cases/hr	Total Cases
Root Mean Square Error (RMSE)	.01	.44
Mean Square Error (MSE)	0.00	.19
Bias	.52	.42
Variation	.48	.58
Covariation	0.00	0.00

*Table 1: Theil statistics derived from the comparing the output from the modeled Surat outbreak to the actual data from Surat.*

---

For both parameters tested, the Theil statistics confirm the closeness of the model’s output to the compiled hospital statistics. The extremely low Root Mean Square Error values are encouraging, in the sense that they suggest that this model does not have glaringly obvious errors in basic structures or parameters. As Sterman (2000) forcefully points out, however, this test does NOT “confirm” the model as a correct representation of the system or that it will continue to be reliable outside the current range of its application. The bias, variation, and covariation inequality statistics are presented for completeness.

**Summary:** The preceding material is basically a progress report on a partially complete study of modeling human behavior, decision making, and policy-setting in the context of pneumonic plague. We strived to develop a model of pneumonic plague moving through a bounded human population during a relatively short-lived outbreak or epidemic. That modeled outbreak might be natural or the result of bioterrorism and community might be large or small. The model parameters were drawn from careful prior analyses of plague and the feedback structures and their implications tested through comparison with a recent and well-documented natural outbreak in Surat, India. Three types of human behavior were applied exogenously to this modeled scenario:

1. Fight: through the application of antibiotics for treatment and for prophylaxis, although the latter application was deliberately modeled with only imperfect protection being conferred.
2. Flight: through the consideration of a portion of the city’s population fleeing on hearing of the outbreak and the realization that insufficient stocks of antibiotics were available to protect those not yet symptomatic.
3. Freeze: through the voluntary reduction of contacts among and between the remaining inhabitants of the city.

Collectively, these three behaviors are sufficient to reproduce the observed behavior of the outbreak.



**Modeling Pneumonic Plague in the Future:** While the imposition of reasonable exogenous behavioral factors allows *ex post facto* duplication of the outbreak dynamics, it provides little assistance in understanding what interactions or feedbacks gave rise to those specific behaviors, their time courses, or their intensities. Use of this model as a predictive tool to guide a response to a future outbreak is, therefore, of limited value or reliability. Our task, as we continue into a second year of this project, is to identify a number of mental models used by the social science fields to explain judgment and decision-making, translate those theories into stock and flow templates, and apply them to this particular situation in an effort to make these behaviors endogenous and, therefore, responsive to the developing situation. If we can limit the defining parameters to a manageably small number, this will provide a first-generation model that can be adapted and fine-tuned to provide policy guidance in a wide variety of settings.

**References:**

- Bombard, J. N. Jr. 2001. Primary Pneumonic Plague Transmission and BW Casualty Assessments. Unpublished Draft. Institute for Defense Analysis Paper P-3657. 138 pp.
- Canada Newswire. 2003. ID Biomedical announces new data from Plague vaccine. <http://www.newswire.ca/releases/May2003/05/c7615.html>. (Posted 5 May 2003; Accessed 16 May 2003).
- Garrett, L. 2000. Betrayal of Trust: The Collapse of Global Public Health (New York: Hyperion). 754 pp.
- Shah, G. 1997. Public Health and Urban Development: The Plague in Surat. New Delhi: Sage Publications. 317 pp.
- Sterman, John D. 2000. Business Dynamics: Systems Thinking and Modeling for a Complex World. (New York: Irwin McGraw Hill). 982 pp.